



Calibration of flow meters according to DIN EN ISO/IEC 17025:2005

Introduction	2
Calibration laboratory	3
Description of the calibration process.....	3
Calibration according to the weighing-time procedure....	4
Hydraulic circuit.....	8
Performance data for the permanent laboratory.....	8
DAkkS Accreditation.....	9

Table of contents

Calibration is the professional method for obtaining precise and accurate information about the accuracy of measuring equipment. As a manufacturer of flow meters, we prepare individual calibration records for all sensors; by request also for two flow directions and different viscosities.

Our calibration records contain:

- K-factor and linearity error for the entire measuring range
- K-factor and linearity error at various measuring points

You have the choice of our gravimetric or volumetric test stands for the calibration.

The gravimetric calibration stand is the heart of our DAkkS-DKD-AHT311 (EA-4/02) calibration laboratory. The laboratory is accredited according to ISO 4185 by the accreditation authority of the German Calibration Service



Calibration laboratory

Calibration procedure

According to ISO 4185: Measurement of liquids in closed pipelines – weighing procedure

Description of the calibration process

This dynamic calibration procedure uses the weighing-time system (self-indicating), i.e. the corresponding required volume of liquid with a specified weight is measured in the time unit under consideration of the specific weight and viscosity, while the specified temperature of the test medium is kept constant with high accuracy.

For the exact determination of the volume flow, an online density measuring device from the company Anton Paar, model L-Dens 417, is used in parallel to record the density for each measuring point. The sensor itself is equipped with internal temperature measurement (± 0.1 °C), so that the density can be determined exactly (± 0.0001 kg/m³). Therefore the same also applies to the resulting calculated volume.

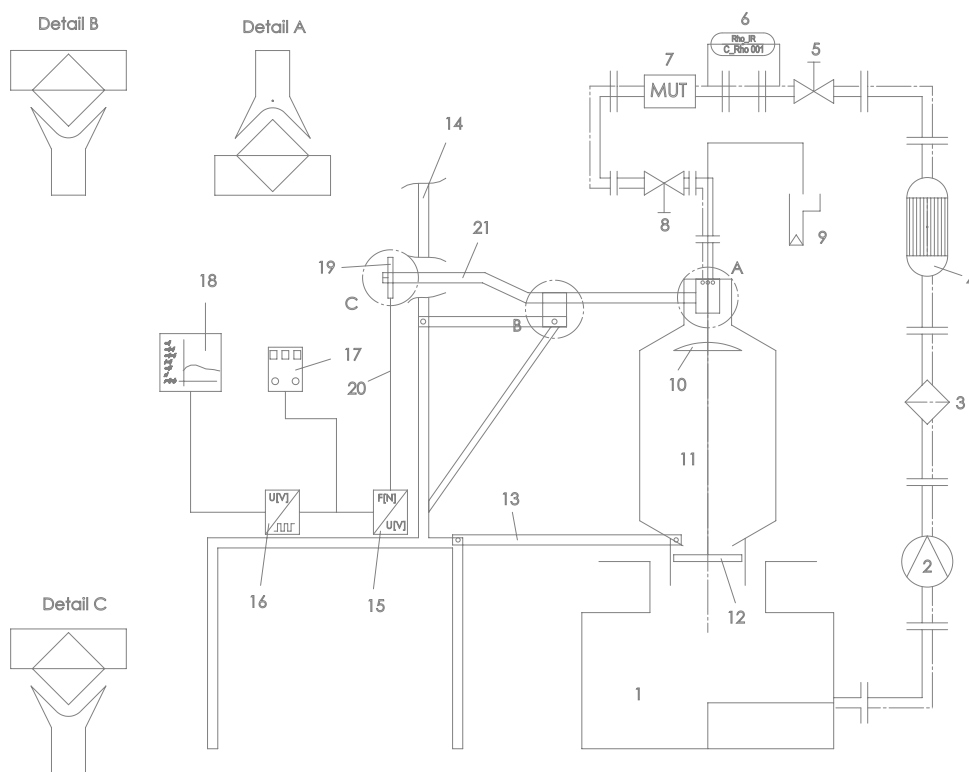

Fig. 8-1: Schematic drawing of the weighing system

Δ s: deflection of the lever arm; 1: storage tank; 2: centrifugal pump; 3: filtering unit; 4: tube-bundle-heat exchanger; 5: control valves; 6: specimen; 7: balancing valves; 8: pneumatikator for closing and opening the valve at the weighing tank bottom (11); 9: baffle plate for returning the kinetic/potential energy of the medium of the housing of the weighing tank (10); 10: weighing tank; 11: valve for opening/closing the weighing tank; 12: rigid, mechanical linkage; 13: test stand frame; 14: weighing cell; 15: A/D transformer; 16: timer/counter; 17: DOP software; 18: stellite cutting edge; 19: steel cable connection to the weighing cell; 20: weighing arm; detail A, B, C: storage of cutting and saddle

Gravimetrischer Kalibrierstand AHT311
(EA-4/02)

- Measuring range: 0,016 to 2,000 l/min
- Calibration viscosities: up to 100 mm/s
- Measuring uncertainty: 0,05%-0,1% of the measurement

Calibration according to the weighing time procedure

During calibration, the time is measured in which a previously determined precision weight (established mass) is compensated by the calibration medium after it flows through the specimen.

An electronic msec timer precisely captures the duration of each weighing process. The timer oscillation is 1 MHz.

In order to guarantee the high accuracy and reproducibility of the measurements, all components of the calibration stand are harmonised for the application.

The self-indicating weighing system described above is used to measure the time in which a previously established calibration fluid is collected in the weighing tank after it flows through the specimen.

The weighing tank is suspended from a weighing arm, at the end of which is a load cell with accuracy C3 according to OIML R60. An electronic deflection system is used, which drastically reduces the lever stroke (see Fig. 8-1). The connection between the weighing arm and load cell is rigid, so that the risk of a time offset at this point is eliminated as well. The measuring signal from the load cell is evaluated by a high-quality digital measuring amplifier for dynamic weighing processes and displayed on the computer with DOP software which is used for further processing.

To counteract undesirable friction forces, the scale is stabilised by self-aligning Stellite blades and Wallex saddles.

This guarantees a constant, unchanging lever arm. The sensitivity of the entire system in response to weight changes is unusually high.

An electronic millisecond counter is used to measure the precise duration of each weighing process. The counter oscillation is 1 MHz. The display is in thousandths of a second.

For the calibration of pulse-generating flow meters, such as turbine flow meters, a pulse counter captures the current and overall pulse rate.

The pulse counter is linked to the millisecond counter.

All components are designed especially for this measuring application and guarantee optimum flow conditions with the highest reliability.

Flow rate

The liquid in the reservoir is continuously pumped through a closed hydraulic circuit (see Fig. 8-2). It first flows through the filter (1) and heat exchanger (2), which keeps the temperature and therefore the viscosity of the calibration medium constant. Then the test liquid flows through the control valves (3), density measuring device (4), specimen (5), balancing valve (6), weighing tank (7) and finally back into the reservoir (8). A deflection cone at the intake of the weighing tank ensures even distribution of the calibration liquid in the tank.

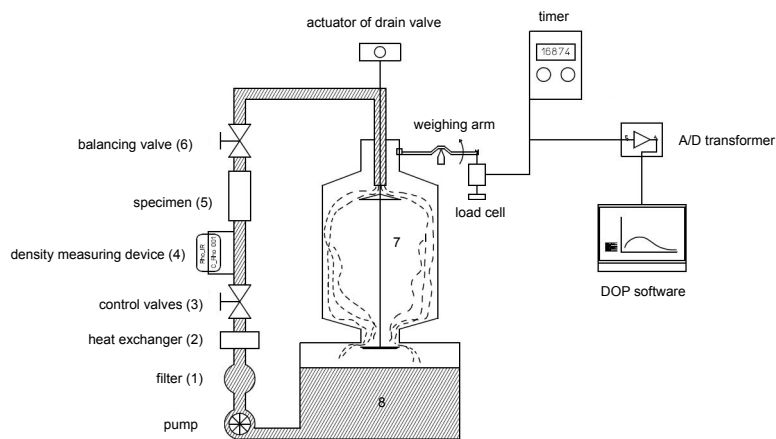

Fig. 8-2: Weighing system – flow rate

Preparing for the weighing process

The control valves (1) are set to the desired flow rate. The duration of calibrating the measuring point is determined by entering weight values in the DOP software (2) (setpoint 0 = tare weight; setpoint 1 = calibration weight) (Fig. 8-3)..

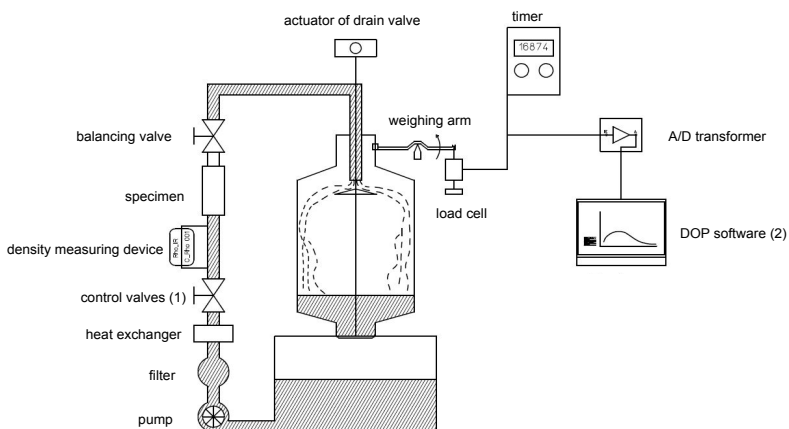

Fig. 8-3: Weighing system – preparing for the weighing process

Forerun/taring phase

Pressing the start button sets the timer (1) to zero and closes the drain valve (2) on the weighing tank, launching the forerun/taring phase of the calibration process (Fig. 8-4).

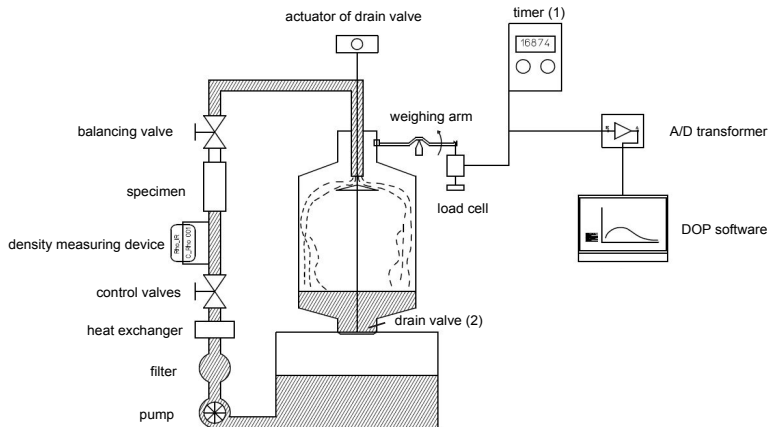

Fig. 8-4: Weighing system – taring phase

End of the forerun/taring phase - start of the weighing process

The load cell (1) measures the weight increase caused by the calibration liquid flowing into the weighing container (2) and sends its signal to the A/D transformer (3). When the weight value stored under setpoint 0 is reached, the A/D transformer (3) activates the timer (4) in the test stand. This is the beginning of the actual weighing process. The taring phase zeroes the scale, compensating for dynamic effects. (Fig. 8-5)

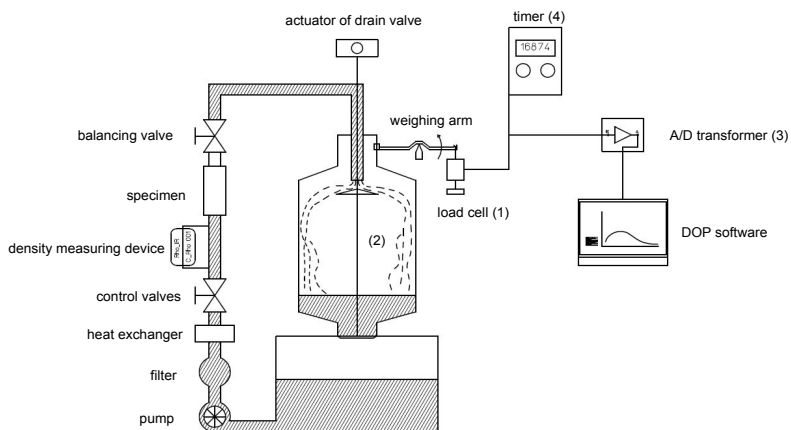

Fig. 8-5: Weighing system – start of the weighing process

End of the weighing process

The weighing process ends and time measurement stops as soon as the specified weight value (setpoint 1) is reached. The measured time is displayed to one thousandth of a second. Now the mass flow rate per unit of time is determined from the measured time and calibration weight (setpoint 1 – setpoint 0) (Fig. 8-6).

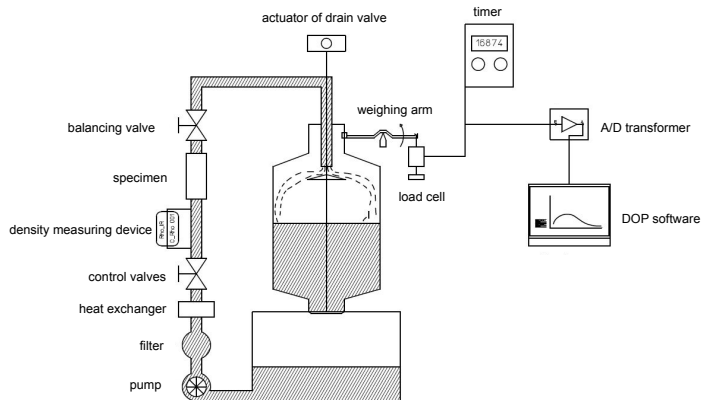

Fig. 8-6: Weighing system – end of the weighing process

Emptying the weighing tank for a new weighing process

When a weighing process has been completed, the weighing tank (1) is emptied automatically (Fig. 8-7). This is done in less than 25 seconds even with the maximum flow rate. A new weighing process can follow immediately after emptying.

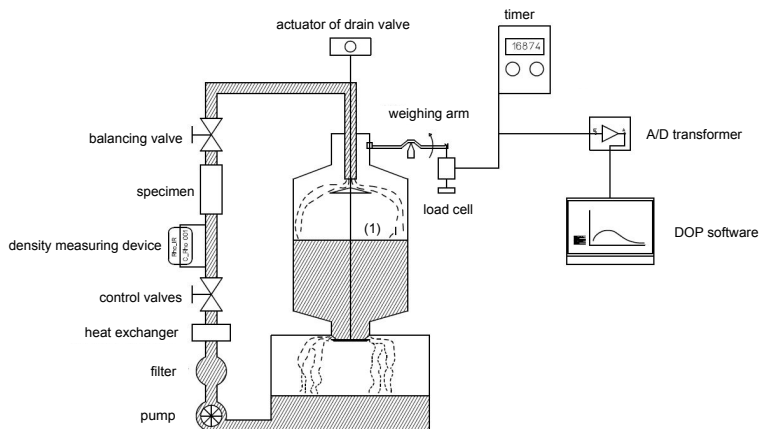
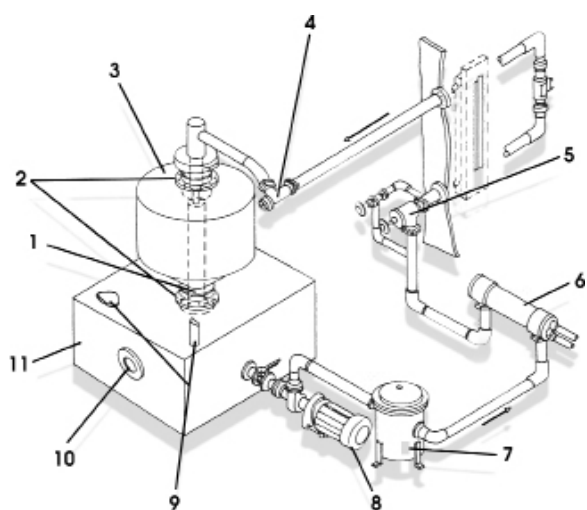

Fig. 8-7: Weighing system – emptying the weighing tank for a new weighing cycle



Hydraulic circuit¹⁾

1. Drain valve for leakage-free operation and high flow rates. With the maximum flow rate, the weighing tank can be emptied in 25 seconds or less without reducing the flow rate.
2. The vapour seals at the top and bottom of the weighing chamber prevent vapour losses. The seals are fluid and free of wear.
3. The stainless steel weighing tank has an overflow for the maximum flow rate.
4. Backpressure regulation prevents cavitation, which can occur in case of liquids with a low viscosity.
5. The flow regulator works with valves developed by COX Instrument for precise flow rate values, ensuring high calibration accuracy.
6. The heat exchanger ensures for a constant temperature of the calibration medium
7. The filter prevents dirt from impairing the performance of the specimen or accumulating in the collection container. Flow turbulences are also prevented by the filter.
8. Corrosion-resistant *precision centrifugal pump*. The pump guarantees a constant flow rate with minimal pulsation.
9. Filler neck. The tank can be filled manually or by external pressure fuelling.
10. The viewing window allows the user to inspect the collection container and drain valve at any time. A leak in the drain valve can be identified immediately.
11. The reservoir is made of stainless steel and is self-draining. This is important when changing liquids.

Permanent Laboratory

Measurement or calibration object	Measuring range/ measuring span	Measuring conditions/ processes	Smallest assignable measuring uncertainty	Notes
Flow rate measurements				
Mass m of flowing liquids	0,9 kg to 8 kg 90 kg to 600 kg	Weighing process Dynamic	0,05 %	Medium being measured; liquids with a density of $\rho = 650 \text{ kg/m}^3$ to $\rho = 1000 \text{ kg/m}^3$ and a viscosity of $\nu = 1 \text{ mm}^2/\text{s}$ $\nu = 100 \text{ mm}^2/\text{s}$
Measured flow rate dm/dt of flowing liquids	0,015 kg/min to 1500 kg/min			
Volume V of flowing liquids	1 l to 10 l 100 l to 800 l	Weighing process Dynamic Conversion via the density	0,1 %	
Flow rate dV/dt of flowing liquids	0,016 l/min to 2000l/min			

¹⁾ The smallest assignable measuring uncertainties are established according to DAkkS-DKD-3 (EA-4/02). These are extended measuring uncertainties with a 95% coverage probability and, unless anything different is specified, have the coverage factor $k=2$. Measuring uncertainties without specified units are relative values referring to the measurement, unless otherwise noted.

Deutsche Akkreditierungsstelle GmbH
German Accreditation Body

Annex to the Accreditation Certificate D-K-15166-01-00
according to DIN EN ISO/IEC 17025:2005

Period of validity: 2014-10-28 to 2017-01-24

Date of issue: 2014-10-28

Holder of certificate:

KEM Küppers Elektromechanik GmbH
Liebigstraße 5, 85757 Karlsfeld

with calibration laboratory:

KEM Küppers Elektromechanik GmbH
Wetzeller Straße 22, 93444 Bad Kötzing

Head:	Anton Gams
Deputy:	Stefan Aschenbrenner
	Thomas Steuer
	Florian Breu

Accredited since: 1984-07-06

Calibrations in the fields:

Fluid Quantities

- **Liquid flow rate**
- **Volume of flowing liquids**
- **Mass of flowing liquids**

Permanent Laboratory

Measured quantity / Calibration item	Range	Measurement conditions / procedure	Best measurement capability ¹⁾	Remarks
flow quantities				
mass <i>m</i> of flowing liquids	0,9 kg to 8 kg	dynamic weighing method	0,05 %	Measured fluid: fluids with a density from $\rho = 650 \text{ kg/m}^3$ to $\rho = 1000 \text{ kg/m}^3$ and a viscosity from $\nu = 1 \text{ mm}^2/\text{s}$ to $\nu = 100 \text{ mm}^2/\text{s}$
	90 kg to 600 kg			
Mass flow rate <i>dm/dt</i> of flowing liquids	0,015 kg/min to 1500 kg/min			
volume <i>V</i> of flowing liquids	1 ℓ to 10 ℓ	dynamic weighing method; conversion by using density	0,1 %	
	100 ℓ to 800 ℓ			
volume flow rate <i>dV/dt</i> of flowing liquids	0,016 ℓ/min to 2000ℓ/min			

¹⁾ The best measurement capabilities are stated according to DAkks-DKD-3 (EA-4/02). These are expanded uncertainties of measurement with a coverage probability of 95 % and have a coverage factor of $k = 2$ unless stated otherwise. Uncertainties without unit are relative uncertainties referring to the measurement value unless stated otherwise.

KEM Headquarter

Liebigstraße 5
85757 Karlsfeld
Deutschland

T. +49 8131 59391-0
F. +49 8131 92604

info@kem-kueppers.com

KEM Service & Repairs

Wetzeller Straße 22
93444 Bad Kötzing
Deutschland

T. +49 9941 9423-0
F. +49 9941 9423-23

info@kem-kueppers.com

*For more distributors & partners, please visit:
www.kem-kueppers.com*